



INFORMATIVO TÉCNICO

Technical Information

Visando a praticidade de aplicação em casos específicos, notar que:

Aiming at the practicality of application in specific cases, note that:

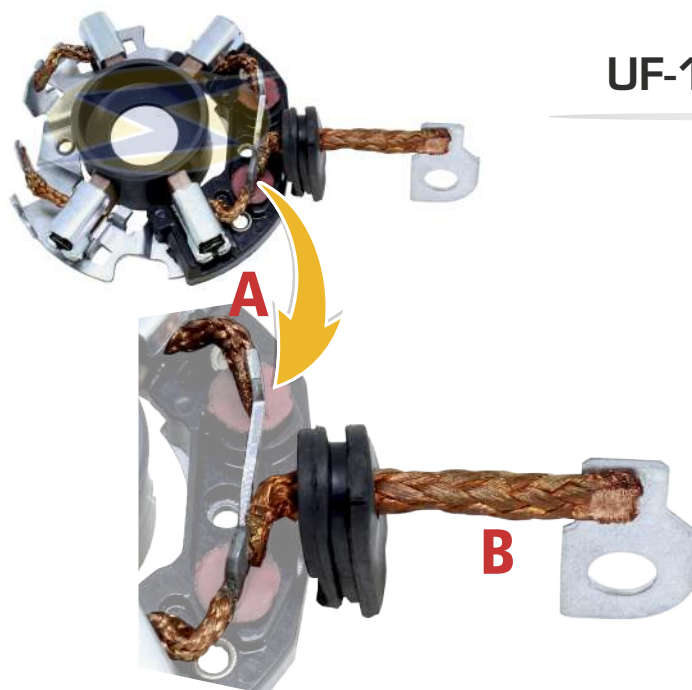

UF-1.315/4

UF-1.315/4, PERMITE SUBSTITUIR OS SEGUINTE 2 PRODUTOS:

UF-1.315/4, PERMITS TO REPLACE THE FOLLOWING 2 PRODUCTS:



UF-1.115/4



UF-1.116/4

Esta peça unifica a aplicação de dois modelos, e há a garantia de qualidade de condutibilidade de corrente equiparado ao produto original, visto que foi mantido o terminal de ligação entre cabo e escova (Detalhe "A") e reforçado a cordoalha até o terminal do solenoide (detalhe "B").

ATTENTION: This piece unifies the application of two models, and there is the guarantee of energy transferation quality equivalent to the OEM brush holder project, because was maintained the steel connection terminal (Detail "A ") and reinforced the carbon/solenoid cable (detail "B").

UF-1.317/4

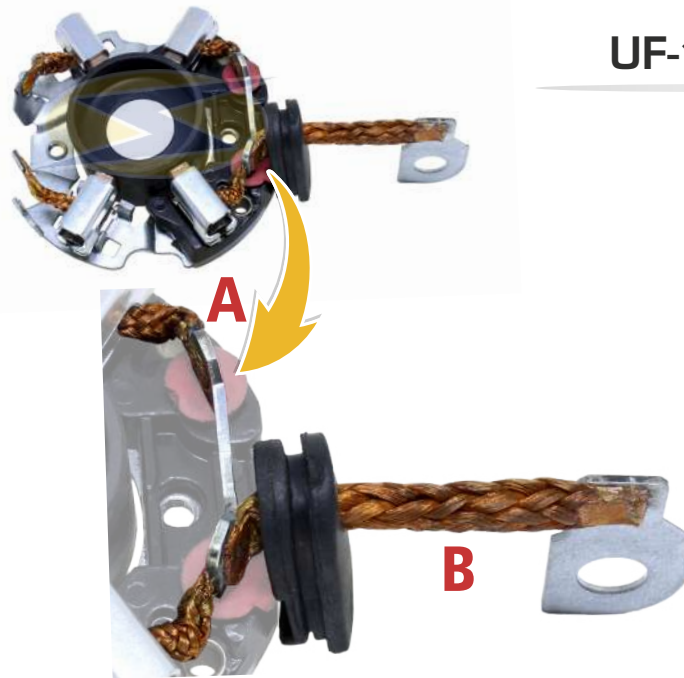

UF-1.317/4, PERMITE SUBSTITUIR OS SEGUINTE 3 PRODUTOS:

UF-1.317/4, PERMITS TO REPLACE THE FOLLOWING 3 PRODUCTS:



UF-1.117/4



UF-1.118/4



UF-1.119/4

Esta peça unifica a aplicação de três modelos, e há a garantia de qualidade de condutibilidade de corrente equiparado ao produto original, visto que foi mantido o terminal de ligação entre cabo e escova (Detalhe "A") e reforçado a cordoalha até o terminal do solenoide (detalhe "B").

ATTENTION: This piece unifies the application of three models, and there is the guarantee of energy transferation quality equivalent to the OEM brush holder project, because was maintained the steel connection terminal (Detail "A ") and reinforced the carbon/solenoid cable (detail "B").



INFORMATIVO TÉCNICO

Technical Information

Visando a praticidade de aplicação em casos específicos, notar que:
 Aiming at the practicality of application in specific cases, note that:



UF-1.223/4

UF-1.223/4, PERMITE SUBSTITUIR OS SEGUINTE 7 PRODUTOS:

UF-1.223/4, PERMITS TO REPLACE THE FOLLOWING 7 PRODUCTS:



UF-1.263/4



UF-1.264/4



UF-1.265/4



UF-1.266/4



UF-1.267/4



UF-1.277/4



UF-1.278/4

ATENÇÃO: Recomendamos esta unificação numa situação de falta de estoque ou necessidade extrema. Os modelos que podem ser "substituídos" aconselhamos manter em linha, pois eles seguem o padrão original da montadora, tendo cada um suas características de montagem no motor de partida. (Cabo, Terminal, etc.)

ATTENTION: We recommend this unification in a situation of lack of inventory or extreme need. The models that can be "replaced" should be kept in line, as it follows the OEM project, each one having the mounting characteristics in the starter. (Cable, Terminal, etc.)



UF-1.224/4

UF-1.224/4, PERMITE SUBSTITUIR O SEGUINTE PRODUTO:

UF-1.224/4, PERMITS TO REPLACE THE FOLLOWING PRODUCT:



UF-1.226/4

ATENÇÃO: Recomendamos esta unificação numa situação de falta de estoque ou necessidade extrema. Os modelos que podem ser "substituídos" aconselhamos manter em linha, pois eles seguem o padrão original da montadora, tendo cada um suas características de montagem no motor de partida. (Cabo, Terminal, etc.)

ATTENTION: We recommend this unification in a situation of lack of inventory or extreme need. The models that can be "replaced" should be kept in line, as it follows the OEM project, each one having the mounting characteristics in the starter. (Cable, Terminal, etc.)



UF-1.225/4

UF-1.225/4, PERMITE SUBSTITUIR OS SEGUINTE 4 PRODUTOS:

UF-1.225/4, PERMITS TO REPLACE THE FOLLOWING 4 PRODUCTS:



UF-1.280/4



UF-1.281/4



UF-1.279/4



UF-1.282/4

ATENÇÃO: Recomendamos esta unificação numa situação de falta de estoque ou necessidade extrema. Os modelos que podem ser "substituídos" aconselhamos manter em linha, pois eles seguem o padrão original da montadora, tendo cada um suas características de montagem no motor de partida. (Cabo, Terminal, etc.)

ATTENTION: We recommend this unification in a situation of lack of inventory or extreme need. The models that can be "replaced" should be kept in line, as it follows the OEM project, each one having the mounting characteristics in the starter. (Cable, Terminal, etc.)



UF-1.128/4

UF-1.128/4, PERMITE SUBSTITUIR OS SEGUINTE 2 PRODUTOS:

UF-1.128/4, PERMITS TO REPLACE THE FOLLOWING 2 PRODUCTS:



UF-1.129/4



UF-1.194/4

ATENÇÃO: Recomendamos esta unificação numa situação de falta de estoque ou necessidade extrema. Os modelos que podem ser "substituídos" aconselhamos manter em linha, pois eles seguem o padrão original da montadora, tendo cada um suas características de montagem no motor de partida. (Cabo, Terminal, etc.)

ATTENTION: We recommend this unification in a situation of lack of inventory or extreme need. The models that can be "replaced" should be kept in line, as it follows the OEM project, each one having the mounting characteristics in the starter. (Cable, Terminal, etc.)



INFORMATIVO TÉCNICO

Technical Information

Visando a praticidade de aplicação em casos específicos, notar que:

Aiming at the practicality of application in specific cases, note that:



UF-1.268/4

UF-1.268/4, PERMITE SUBSTITUIR O SEGUINTE PRODUTO:

UF-1.268/4, PERMITS TO REPLACE THE FOLLOWING PRODUCT:



UF-1.270/4

ATENÇÃO: Recomendamos esta unificação numa situação de falta de estoque ou necessidade extrema. Os modelos que podem ser "substituídos" aconselhamos manter em linha, pois eles seguem o padrão original da montadora, tendo cada um suas características de montagem no motor de partida. (Cabo, Terminal, etc.)

ATTENTION: We recommend this unification in a situation of lack of inventory or extreme need. The models that can be "replaced" should be kept in line, as it follows the OEM project, each one having the mounting characteristics in the starter. (Cable, Terminal, etc.)



UF-1.283/4

UF-1.283/4, PERMITE SUBSTITUIR O SEGUINTE PRODUTO:

UF-1.283/4, PERMITS TO REPLACE THE FOLLOWING PRODUCT:



UF-1.269/4

ATENÇÃO: Recomendamos esta unificação numa situação de falta de estoque ou necessidade extrema. Os modelos que podem ser "substituídos" aconselhamos manter em linha, pois eles seguem o padrão original da montadora, tendo cada um suas características de montagem no motor de partida. (Cabo, Terminal, etc.)

ATTENTION: We recommend this unification in a situation of lack of inventory or extreme need. The models that can be "replaced" should be kept in line, as it follows the OEM project, each one having the mounting characteristics in the starter. (Cable, Terminal, etc.)



UF-1.307/4

UF-1.307/4, PERMITE SUBSTITUIR OS SEGUINTE 4 PRODUTOS:

UF-1.307/4, PERMITS TO REPLACE THE FOLLOWING 4 PRODUCTS:



UF-1.256/4



UF-1.271/4

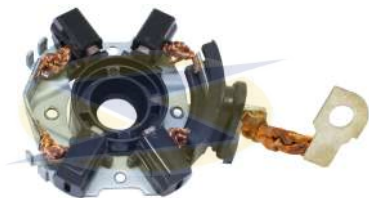

UF-1.272/4

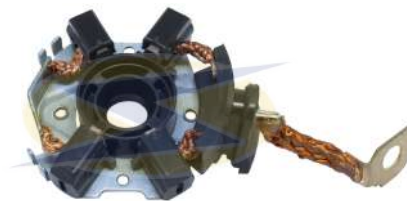

UF-1.276/4

ATENÇÃO: Recomendamos esta unificação numa situação de falta de estoque ou necessidade extrema. Os modelos que podem ser "substituídos" aconselhamos manter em linha, pois eles seguem o padrão original da montadora, tendo cada um suas características de montagem no motor de partida. (Cabo, Terminal, etc.)

ATTENTION: We recommend this unification in a situation of lack of inventory or extreme need. The models that can be "replaced" should be kept in line, as it follows the OEM project, each one having the mounting characteristics in the starter. (Cable, Terminal, etc.)

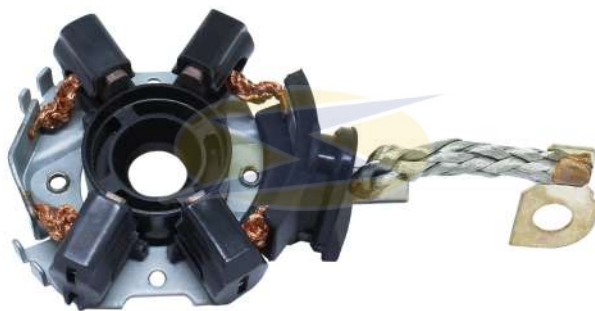

UF-1.275/4

UF-1.275/4, PERMITE SUBSTITUIR OS SEGUINTE 2 PRODUTOS:

UF-1.275/4, PERMITS TO REPLACE THE FOLLOWING 2 PRODUCTS:



UF-1.273/4



UF-1.274/4



UF-1.310/4

ATENÇÃO: Recomendamos esta unificação numa situação de falta de estoque ou necessidade extrema. Os modelos que podem ser "substituídos" aconselhamos manter em linha, pois eles seguem o padrão original da montadora, tendo cada um suas características de montagem no motor de partida. (Cabo, Terminal, etc.)

ATTENTION: We recommend this unification in a situation of lack of inventory or extreme need. The models that can be "replaced" should be kept in line, as it follows the OEM project, each one having the mounting characteristics in the starter. (Cable, Terminal, etc.)